



Bukkemaskiner - manuelle



Biegemaschinen - manuell



Folding machines - manual

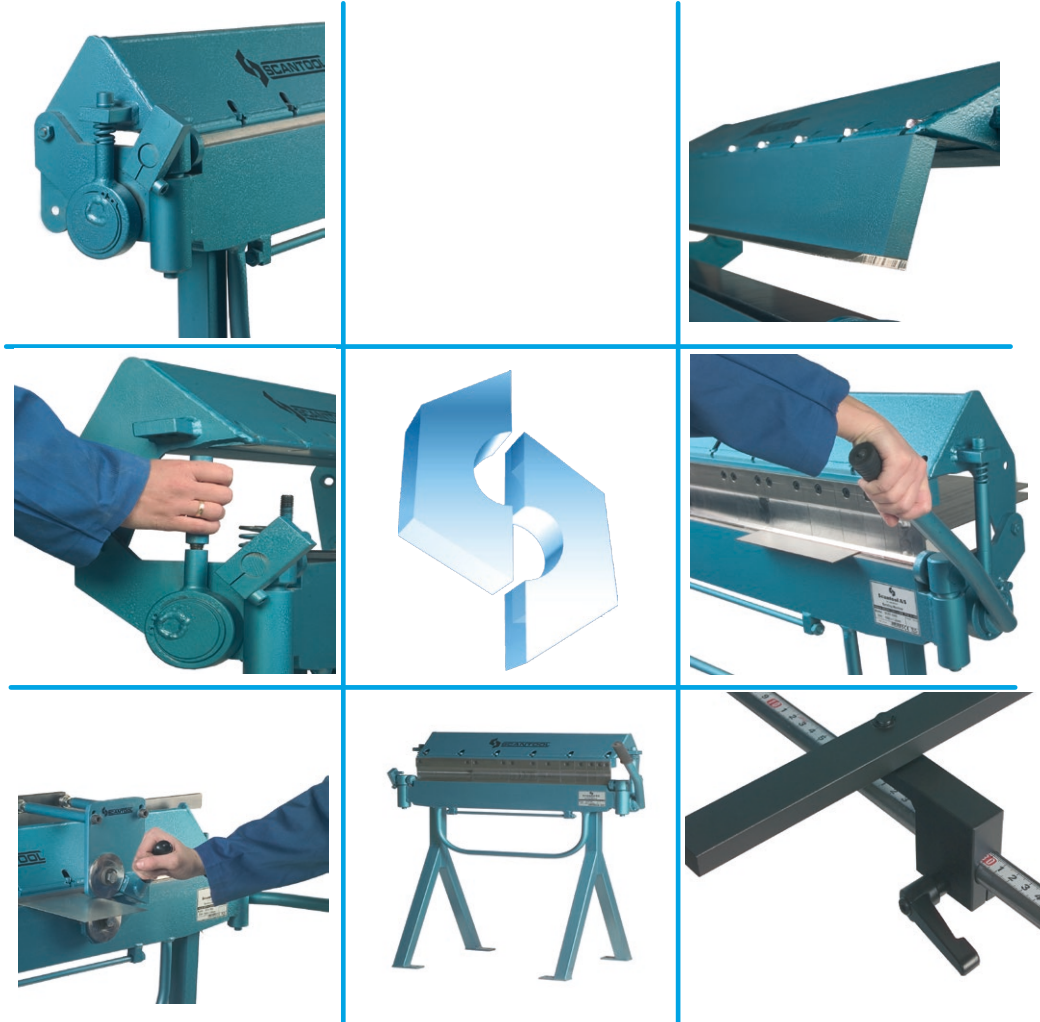

DK

- Dansk topkvalitet indtil mindste detalje
- Overvagen er specielt konstrueret med særligt forspænd, så man undgår indstilling til forskellige pladetykkelser
- Selvsmørende glidelejer på alle maskintyper
- Flot finish og moderne industridesign
- SCANTOOL standardmaskiner dækker op til 95 % af alle bukke- opgaver i disse pladedimensioner
- Til helt specielle opgaver kan leveres specialmaskiner efter ønske
- Yderst konkurrencedygtige priser

D

- Dänische Spitzenqualität bis ins kleinste Detail
- Die Oberwange ist mit einem speziellen Vorspann konstruiert, sodass man die Plattenstärke nicht einzustellen braucht
- Selbstschmierende Gleitlager bei allen Maschinentypen
- Tolles Finish und modernes Industriedesign
- Die SCANTOOL-Standardmaschinen decken bis zu 95 % aller Biegeaufgaben mit diesen Plattenstärken ab
- Spezialmaschinen für Sonderaufgaben auf Anfrage erhältlich
- Sehr kostengünstig

GB

- Top quality down to the last detail
- The upper beam has built-in camber, so that the operator will not have to adjust it using different plate thicknesses
- Self-lubricating bearings
- Superior finish and a modern industrial design
- Scantool standard machines cover up to 95 % of all bending work for sheets of these dimensions
- We can offer special tooling on request for specific tasks
- Very competitive prices

- member of a strong family



Bukkemaskiner - manuelle



Biegemaschinen - manuell



Folding machines - manual

SCA 660 / 1050 / 1300



DK Scantool SCA har en lav overvange med særlig forspænd, som tilpasser sig forskellige pladetykkelser. Bukkevængens forspænd kan justeres. Skift fra lav til høj overvange se venligst side 109.

D Scantool SCA hat eine niedrige Oberwange mit speziellem Vorspann, die sich an die verschiedenen Plattenstärken anpasst. Der Vorspann der Biegewange ist justierbar. Für den Umbau von niedriger zu hoher Oberwange siehe Seite 109.

GB Scantool SCA has an upper beam with built-in camber which handles varying sheet thicknesses without adjustment. The distortion is adjustable. To change from low upper beam to high upper beam, please see page 109.

Type	Varenummer	Arbejds længde	Pladetykkelse	Bukke vinkel	Max. åbning	Mål L-B-H	Vægt
Modell	Art.-Nr.	Werklänge	Plattenstärke	Biege vinkel	Max. Öffnung	Maße L-B-H	Gewicht
Type	Article number	Working length	Sheet dimension	Folding angle	Max. opening	Measurement L-W-H	Weight
SCA 660	540 72 1000	660 mm	2 mm	135°	40 mm	890x500x850 mm	52 kg
SCA 1050	540 72 1100	1050 mm	1,25 mm	135°	40 mm	1260x500x940 mm	74 kg
SCA 1300	540 72 1300	1300 mm	1,20 mm	135°	40 mm	1495x500x960 mm	90 kg



Bukkemaskiner manuelle



Biegemaschinen - manuell



Folding machines - manual

SCB 660 / 1050 / 1300

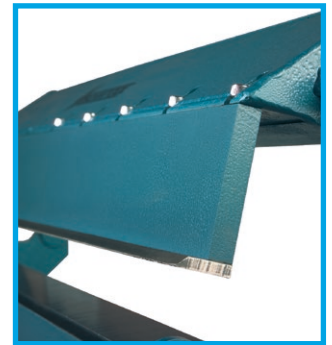
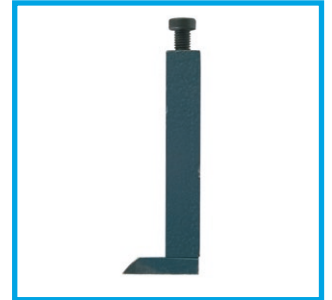

DK Scantool SCB har en høj overvange med særlig forspænd, som tilpasser sig til forskellige pladetykkelser. Bukkevængens forspænd kan justeres. Skift fra høj til lav overvange se venligst side 109.

D Scantool SCB hat eine hohe Oberwange mit speziellem Vorspann, die sich an die verschiedenen Plattenstärken anpasst. Der Vorspann der Biegewange ist justierbar. Für den Umbau von hoher zu niedriger Oberwange siehe Seite 109.

GB Scantool SCB has a high upper beam with built-in camber which handles varying sheet thicknesses without adjustment. The distortion is adjustable. To change from high upper beam to low upper beam, please see page 109.

Type	Varenummer	Arbejds længde	Pladetykkelse	Bukkevinkel	Max. opening	Mål L-B-H	Vægt
Modell	Art.-Nr.	Werklänge	Plattenstärke	Biegewinkel	Max. öffnung	Maße L-B-H	Gewicht
Type	Article number	Working length	Sheet dimension	Folding angle	Max. opening	Measurement L-W-H	Weight
SCB 660	540 72 1600	660 mm	1,8 mm	93°	40 mm	890x500x950 mm	61 kg
SCB 1050	540 72 1700	1050 mm	1,25 mm	93°	40 mm	1270x490x1050 mm	87 kg
SCB 1300	540 72 1900	1300 mm	1,20 mm	93°	40 mm	1495x500x1040 mm	107 kg

- member of a strong family



Bukkemaskiner - manuelle



Biegemaschinen - manuell



Folding machines - manual

SCST 660 / 1050 / 1300

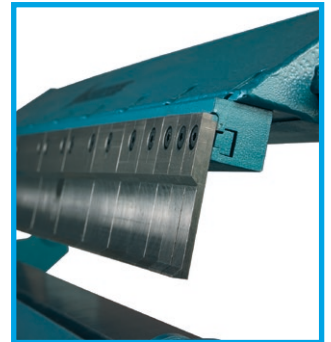
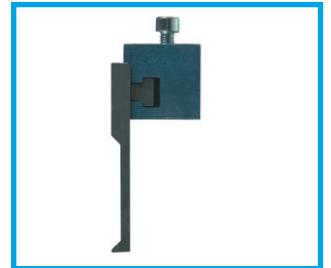



DK Scantool SCST har en høj overvange med segmenter med tåspids og et særlig forspænd, som tilpasser sig til forskellige pladetykkelser. Bukkevængens forspænd kan justeres. Skift fra høj til lav overvange se venligst side 109.

D Scantool SCST hat eine hohe Oberwange mit Segmenten mit Geißfuß und einem speziellen Vorspann, die sich an die verschiedenen Plattenstärken anpasst. Der Vorspann der Biegezwange ist justierbar. Für den Umbau von hoher zu niedriger Oberwange siehe Seite 109.

GB Scantool SCST has a segmented upper beam with base and built-in camber which handles varying sheet thicknesses without adjustment. The distortion is adjustable. To change from high upper beam to low upper beam, please see page 109.

Type	Varenummer	Arbejds længde	Pladetykkelse	Bukkevinkel	Max. åbning	Mål L-B-H	Vægt
Modell	Art.-Nr.	Werklänge	Plattenstärke	Biege Winkel	Max. Öffnung	Maße L-B-H	Gewicht
Type	Article number	Working length	Sheet dimension	Folding angle	Max. opening	Measurement. L-W-H	Weight
SCST 660	540 72 3100	660 mm	1,5 mm	93°	50 mm	890x500x950 mm	63 kg
SCST 1050	540 72 3300	1050 mm	1,2 mm	93°	50 mm	1495x500x960 mm	93 kg
SCST 1300	540 72 3700	1300 mm	1,2 mm	93°	50 mm	1495x500x1070 mm	112 kg

-  **Betjening af kantbukkemaskiner - manuelle**
-  **Bedienung von Schwenkbiegemaschinen - manuell**
-  **Handling of folding machines - manual**



- DK** Med det asymmetriske forspænd på overvangen undgår man indstilling til forskellige pladetykkelser
- D** Mit dem asymmetrischen Vorspann in der Oberwange entfällt das Einstellen für verschiedene Plattenstärken
- GB** The upper beam has built-in camber so that the operator does not have to adjust it for different plate thickness



- DK** Blød eller skarp buk kan her indstilles for hver pladetykkelse
- D** Weiches oder scharfes Biegen kann hier für jede Plattenstärke eingestellt werden
- GB** Soft or sharp bending is adjustable for each plate thickness



- DK** Bukkevinklen kan fastindstilles - en fordel når der skal bukes mange emner i samme vinkel
- D** Der Biegewinkel kann fest eingestellt werden. Dies ist von Vorteil, wenn viele Platten in demselben Winkel gebogen werden sollen
- GB** You can set the bend angle if you wish to bend a large number of sheets at the same angle



- DK** Justering af centertryk på bukkevangen
- D** Einstellung des Mitteldrucks an der Biegewange
- GB** Adjustment of centre pressure on the bending beam

- member of a strong family



Ombygning af kantbukkemasiner - manuelle



Umbau von Schwenkbiegemaschinen - manuell



Conversion of folding machines - manual

DK

Alle kantbukkemasiner i SC serien kan ombygges fra lav til høj og omvendt, samt til en maskine med segmenter

D

Alle Schwenkbiegemaschinen der SC Serie können von niedrig auf hoch oder mit Segmenten ausgestattet werden

GB

All SC type folding machines can convert from low to high and to a machine with segments

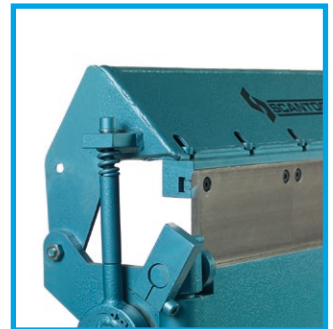
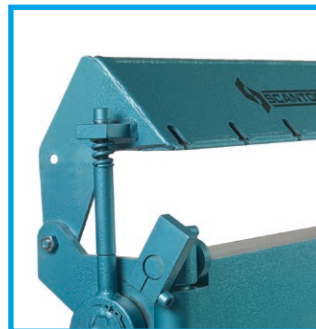

Skarp skinne - Scharfbiegeschiene - Sharp blade

Type	660	1050	1300
	Article no.	Article no	Article no
SCA	58 00 696	58 01 196	58 01 396
SCB	58 00 796	58 01 296	58 01 496



ø 3 mm



Rund skinne - Rundbiegeschiene - Round blade

Type	SCA 660	SCA 1050	SCA 1300
diameter	Article no.	Article no	Article no
3 mm	58 03 599	58 03 699	58 03 899
4 mm	58 03 696	58 03 700	58 03 900
5 mm	58 03 698	58 03 701	58 03 901



ø 4 mm



ø 5 mm



High upper beam



Ombygning - Umbau - Conversion lav til høj - von niedrig nach hoch - low to high

Type	SCA 660	SCA 1050	SCA 1300
No.	Article no.	Article no	Article no
1	15 81 000	15 82 000	15 83 000
2	15 81 100	15 82 100	15 83 100
3	15 81 200	15 82 200	15 83 200

Forlængerbolt
Verlängerungsbolzen
Extension bolt

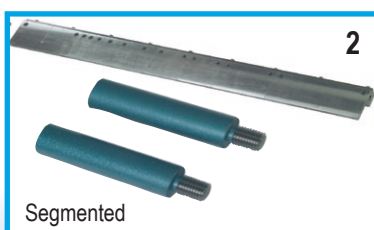

Segmented

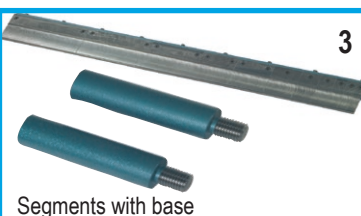

Segments with base



Article number 02 03 008



Tilbehør kantbukkemaskiner - manuelle



Zubehör zu Schwenkbiegemaschinen - manuell



Accessories Folding machines - manual

DK

På alle kantbukkemaskiner i SC serien med lav overvange kan der monteres en rullesaks

D

An allen Schwenkbiegemaschinen in der SC-Serie mit niedriger Oberwange kann eine Rollenschere angebaut werden

GB

All SC type folding machines with low upper beam can be equipped with a roller shear

Rullesaks - Rollenschere - Roller shear

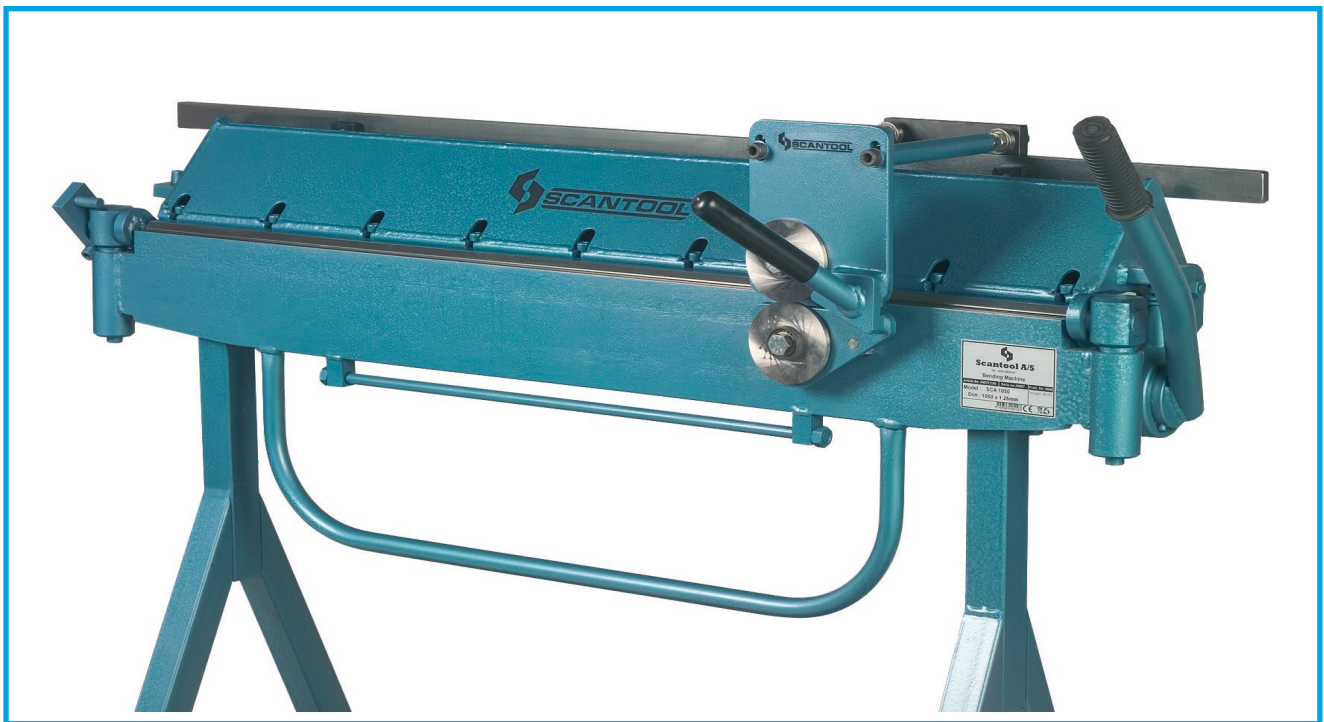

DK

Kan skære plader op til 0,8 mm tykkelse

D

Kann Platten bis zu 0,8 mm Stärke schneiden

GB

The roller shear is able to cut plates up to 0.8 mm thick

Komplet rullesaks
Kompletter Rollenschere
Complete roller shear



- member of a strong family



Tilbehør kantbukkemaskiner - manuelle



Zubehör zu Schwenkbiegemaschinen - manuell



Accessories Folding machines - manual

DK

På alle kantbukkemaskiner i SC serien kan der monteres et pladeanslag

D

An allen Schwenkbiegemaschinen der SC-Serie kann ein Hinteranschlag angebaut werden

GB

All SC type folding machines can be equipped with a back gauge

Pladeanslag - Hinteranschlag - Back gauge



DK

Pladeanslaget kan justeres op til 560 mm

D

Der Hinteranschlag kann auf bis zu 560 mm eingestellt werden

GB

The back gauge can be adjusted to 560 mm

Komplet pladeanslagsæt Kompletter Hinteranschlagsatz Complete back gauge



Type	Varenummer
Modell	Art.-Nr.
Type	Article number
SCA 660	02 30 960
SCA 1050	02 30 910
SCA 1300	02 30 915

 Bukkeeksempler og oversigt over segmentopdeling

 Biegebeispiele und Übersicht der Segmentaufteilung

 Bending examples and segment division

Bukkeeksempler
Biegebeispiele
Bending examples

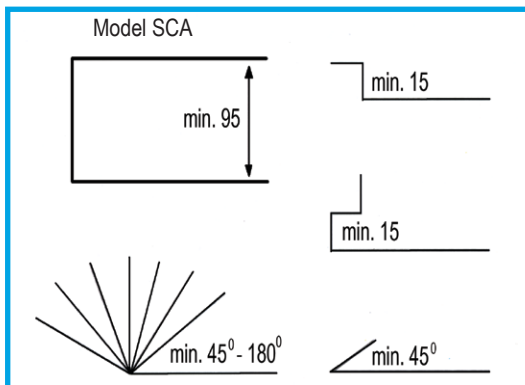

DK

Disse bukkeeksempler viser mulighederne med SC modellerne

D

Diese Biegebeispiele zeigen Möglichkeiten mit den SC-Modellen

GB

These bending examples show the possibilities of the SC models

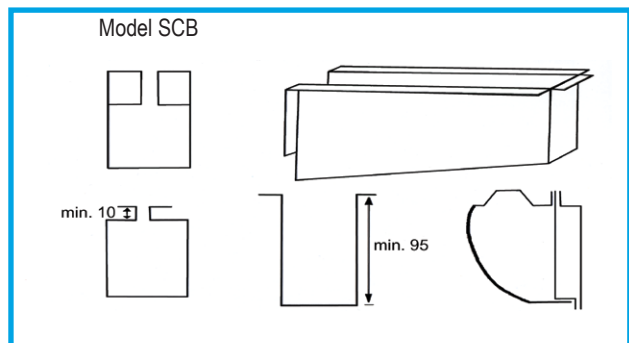
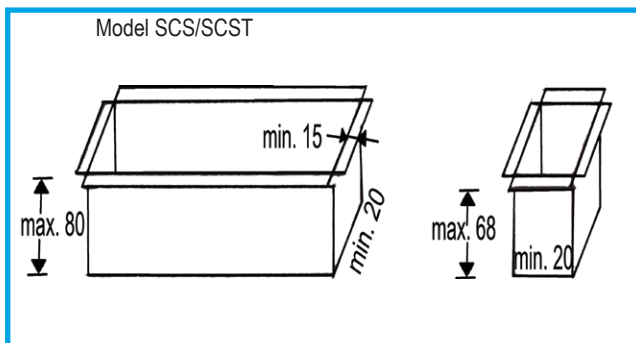

Standard segmentopdeling
Standard-Segmentaufteilung
Standard segment division

Overvangelængde	Segmentbredde i mm
Oberwangenlänge	Segmentbreite in mm
Upper beam length	Segment width in mm
600	25 – 30 – 35 – 40 – 45 – 50 – 75 -100 -250
1000	25 – 30 – 35 – 40 – 45 – 50 – 75 -100 -150 – 200 – 270
1250	25 – 30 – 35 – 40 – 45 – 50 – 75 -100 -150 – 200 – 250 - 270
1500	25 – 30 – 35 – 40 – 45 – 50 – 75 -100 -150 – 200 – 250 – 250 - 270
2000	25 – 30 – 35 – 40 – 45 – 50 – 75 -100 -150 – 200 – 200 - 270 – 400 - 400
2500	25 – 30 – 35 – 40 – 45 – 50 – 75 -100 -150 – 200 – 200 - 270 – 400 – 400 - 500
3000	25 – 30 – 35 – 40 – 45 – 50 – 75 -100 -150 – 200 – 270 – 400 – 500 – 500 - 600

- member of a strong family



Kantbukkemaskiner - hånd- og fodbetjente



Schwenkbiegemaschinen - Hand- und Fußbediente



Folding machines - hand and foot-operated



DK



- Kraftige kantbukkemaskiner med/uden segmentskinne
- Fodbetjent overvange giver operatøren begge hænder fri til indstilling af materialet
- Kraftig hjælpecylinder gør det let for én mand at bukke en stålplade
- Gennemgående skinne uden segmenter kan leveres
- Dansk høj kvalitetsprodukt til konkurrencedygtig pris

D

- Solide Schwenkbiegemaschinen mit/ohne Segmentschiene
- Fußbediente Oberwange - dadurch hat der Bediener beide Hände frei zur Materialjustierung
- Leistungsstarke Hilfszylinder ermöglichen es dem Bediener, eine Stahlplatte zu biegen
- Durchgehende Schiene ohne Segmente erhältlich
- Dänisches Qualitätsprodukt zu einem kostengünstigen Preis

GB

- Heavy-duty bending machines with/without segment beam
- Foot-operated upper beam allows hands free operation
- A heavy-duty cylinder makes the bending of sheets much easier
- The opening between the upper and lower beams can be adjusted
- High-quality Danish products at competitive prices

-  Kantbukkemaskiner - hånd- og fodbetjente
-  Schwenkbiegemaschinen - Hand- und Fußbediente
-  Folding machines - hand and foot-operated

SCAN 10S



DK

- Kraftig kantbukkemaskine med segmentskinne
- Fodbetjent overvange giver operatøren begge hænder fri til indstilling af materialet
- Kraftig hjælpecylinder gør det let for én mand at bukke en stålplade

D



- Solide Schwenkbiegemaschinen mit Segmentschiene
- Fußbediente Oberwange - dadurch hat der Bediener beide Hände frei zur Materialjustierung
- Leistungsstarke Hilfszylinder ermöglichen es dem Bediener, eine Stahlplatte zu biegen

GB

- Heavy-duty bending machines with segment beam
- Foot-operated upper beam allows hands free operation
- A heavy-duty cylinder makes bending of sheets much easier

Type	Varenummer	Arbejds længde	Pladetykkelse	Bukke vinkel	Max. åbning	Mål L-B-H	Vægt
Modell	Art.-Nr.	Werklänge	Plattenstärke	Biegewinkel	Max. Öffnung	Maße L-B-H	Gewicht
Type	Article number	Working length	Sheet dimension	Folding angle	Max. opening	Measurement L-W-H	Weight
SCAN 10S	541 60 1210	1020 mm	2,5 mm	135°	52 mm	1360x800x1140 mm	310 kg

- member of a strong family

-  Kantbukkemaskiner - hånd- og fodbetjente
-  Schwenkbiegemaschinen - Hand- und Fußbediente
-  Folding machines - hand and foot-operated

SCAN 13S



DK

- Kraftig kantbukkemaskine med/uden segmentskinne
- Fodbetjent overvange giver operatøren begge hænder fri til indstilling af materialet
- Kraftig hjælpecylinder gør det let for én mand at bukke en stålplade

D

- Solide Schwenkbiegemaschinen mit Segmentschiene
- Fußbediente Oberwange - dadurch hat der Bediener beide Hände frei zur Materialjustierung
- Leistungsstarke Hilfszylinder ermöglichen es dem Bediener, eine Stahlplatte zu biegen

GB

- Heavy-duty bending machines with/with out segment beam
- Foot-operated upper beam allows hands free operation
- A heavy-duty cylinder makes bending of sheets much easier

Type	Varenummer	Arbejds længde	Pladetykkelse	Bukke vinkel	Max. åbning	Mål L-B-H	Vægt
Modell	Art.-Nr.	Werklänge	Plattenstärke	Biegewinkel	Max. Öffnung	Maße L-B-H	Gewicht
Type	Article number	Working length	Sheet dimension	Folding angle	Max. opening	Measurement L-W-H	Weight
SCAN 13S	541 60 1350	1270 mm	2,0 mm	135°	52 mm	1600x900x1140 mm	340 kg



Betjening af kantbukkemaskiner - hånd- og fodbetjente



Bedienung von Schwenkbiegemaschinen - Hand- und Fußbediente



Handling of folding machines - hand and foot-operated



DK

Kraftig hjælpecylinder gør det let for én mand at bukke en kraftig plade

D

Leistungsstarke Hilfszylinder ermöglichen es dem Bediener, eine starke Platte zu biegen

GB

A heavy-duty cylinder makes bending of sheets much easier



DK

Bukkevinklen kan indstilles og fastlåses for seriemæssige produktioner

D

Der Biegewinkel ist einstellbar und kann für die Serienfertigung festgesetzt werden

GB

The bend angle can be adjusted for the production of series



DK

Overvangen er opdelt i høje segmenter til bukning af kanaler og høje profiler

D

Die Oberwange ist in hohen Segmente zur Biegung von Kanälen und hohen Profilen unterteilt

GB

The machines have a high, segmented upper beam for working with high channels and profiles

Segmentskinne
Segmentschiene
Segmented upper beam

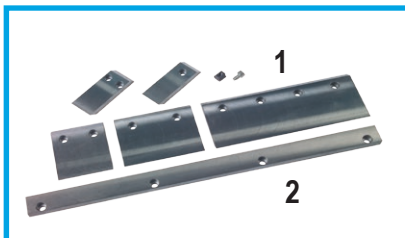

Hjælpecylinder
Hilfszylinder
Heavy-duty cylinder

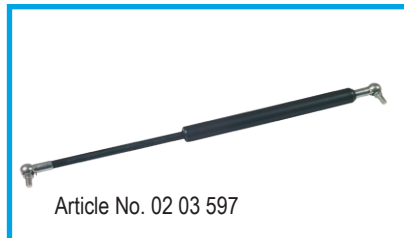

Article No. 02 03 597

Komplet pladeanslagssæt
Kompletter Hinteranslagsatz
Complete back gauge



Type	SCAN 6S	SCAN 10S	SCAN 13S
No.	Article No.	Article No.	Article No.
1	10 55 407	10 55 408	10 55 409
2	01 00 686	01 01 086	01 01 386

Til model	Varenummer
Zum Modell	Art.-Nr.
For model	Article number
SCAN 6S	10 55 435
SCAN 10S	10 56 124
SCAN 13S	10 56 125